

PARKPLUS
HIGH DENSITY VEHICLE STORAGE

LS

LIFT-SLIDING
Semi-Automated
Parking System



SPEC SHEET

PARKPLUS LS LIFT-SLIDING

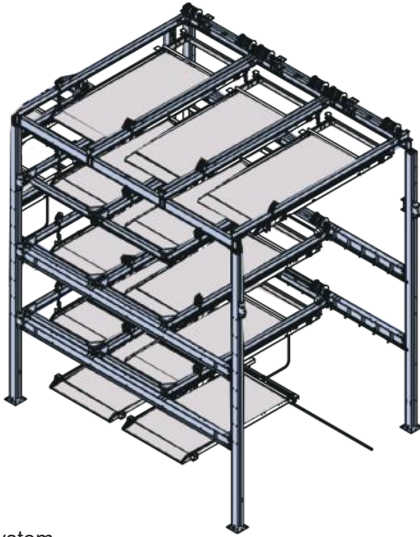

* Typical LS System

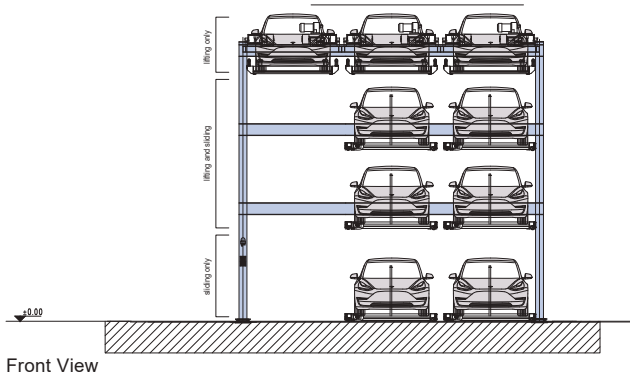

Front View

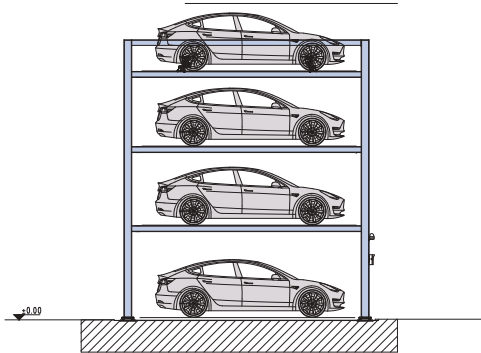

Side View

Applications

Lift-Sliding System can be installed in attended/valet applications and self-park applications:

- Multi-Family Residential Buildings
- Indoor & Outdoor Installations
- Low & High Rise Buildings
- Commercial Buildings
- Surface Lots

The **PARKPLUS** Semi-Automated Lift-Sliding Parking System is a multi-level customizable vehicle storage and retrieval system for storing cars in vertical and horizontal arrays. The Lift-Slide uses Programmable Logic Control (PLC) software to move stacked cars on platforms to receive and present vehicles at grade, providing direct access to stacked vehicles without removing other vehicles from the system.

Entire assembly comes pre-welded and is assembled in the field. System is designed to be mounted on grade with an engineered foundation. System can be designed to stack a up to 5 vehicles above grade and up to 2 vehicles below grade, with a maximum vertical stacking capacity of 7 vehicles in the space usually occupied by a single vehicle. There are no horizontal limitations to the system.

The **PARKPLUS** Lift-Sliding System is designed to be installed indoors and outdoors. System can be customized with external cladding/siding, garage doors and roof, per project specifications. Platform height is set at fixed height between 5'-2" min. and 7'-0" max. Each city may have minimum height requirements and different clear requirements for code required parking. Owner/Architect should review with local planning and building departments. **MEP coordination with project team must meet code requirements and satisfy equipment clearances.**

Suitable for

- Standard passenger vehicles
- SUVs

*Custom solutions available.

Specifications

Load per Platform:	5,200 lbs.
Weight of Unit:	(Determined by Model)
Length of Stall:	19'-9"
Width of Stall:	8'-2 1/2"
Height of Unit:	(Determined by Model)

*Excluding column dimensions of structural framework

*Custom dimensions available

Operation:	Electric Control Panel Programmable Logic Control (PLC) Automatic with Manual Override Push Button Control Key Fob Remote Control (Optional) Mobile App (Optional)
Control:	

Power

Lift Motor: 3HP - 5HP

Traversing Motor: 0.55 HP

Electrical

1 Disconnect required per system module
3 PH 208V (100Amp)-480V (60Amp) /60HZ

All control wiring is a Class 2 Circuit 24V

Power & Electrical specifications vary per Product Model

- Cost-Effective Multi Layered Parking Solution
- In-house Design, Manufacturing, Installation & Service
- Minimal Moving Parts – Reduced Maintenance
- Self Parking – No Attendant Required

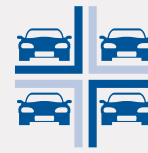

PARKPLUS
HIGH DENSITY VEHICLE STORAGE

Operation

Each module requires an empty stack – allows for shifting of platforms.

User will always park & retrieve car from same position on grade.
Dedicated spaces/platforms can be assigned.

PARKING / STORAGE

- User requests platform by keypad / push-button control, key fob remote control and or mobile app.
- System prepares platform and presents at grade level
- Safety gate opens when platform is in position
- Driver pulls vehicle onto platform
- Driver engages parking brake, shuts off vehicle

* System shown at capacity.

- Driver exits vehicle and completes storage command at keypad
- Safety gate closes
- Vehicle is transferred to specified storage position

RETRIEVAL

- User requests retrieval at keypad
- Process is followed in reverse
- System presents vehicle at same position of loading
- Driver enters vehicle, starts and drives away
- Safety gate closes
- System returns to neutral

A system of safety features ensures normal operation of each cycle.

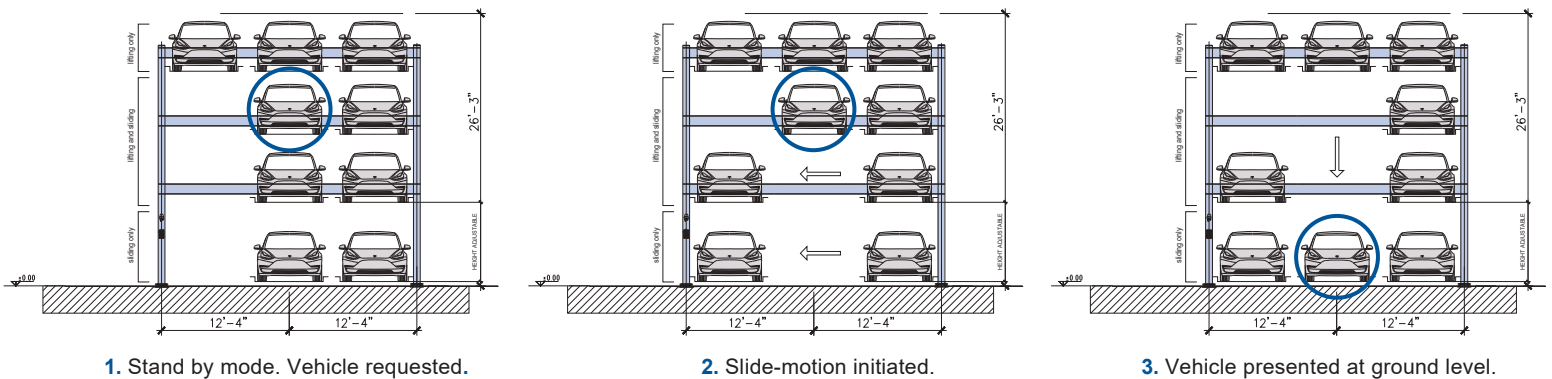

ADDITIONAL INFORMATION

Safety

System is equipped with limit switches which limit motions to correct system levels and positions. Motion detectors and lasers detect obstructions within system and stop operation in emergency. System requires operator reset to check safety and obstruction removal. System is equipped with safety locking system. The safety hook system holds full weight of vehicle on platform in locked position. System is equipped with a secondary (anti-fall) safety system. System is equipped with Visual and Audible alarms and Emergency Stops. Safety Gates are required for Self Parking and In-ground units.

Fire Protecting

In most metropolitan areas, car stacker systems are reviewed as similar to high piled storage and non-building structures. Fire rating of structural components is not required. Sprinklers may be required per following section. Each city may have fire department guidelines.

Fire Sprinklers

Outdoor: 1. Most cities do not require fire sprinklers. 2. May need to conform to additional zoning regulations and building code requirements.

Indoor: 1. Installation shall be in a sprinklered garage. In tandem array, additional sprinkler requirements may apply. 2. Sprinkler Plans filed and approved by local municipality. 3. Sprinkler system designed as required by NFPA 13 and local building codes. 4. Clear building height within parking area must accommodate height of equipment plus additional requirements for adequate coverage of fire sprinklers.

Temperature

This device is designed to operate between 20° and 120° F.

Loading

Structural design and loading is provided on a project by project basis and is dependant on seismic zones, soils conditions and other environmental conditions.

Warranty

12-month Standard Manufacturer's Warranty on new equipment. Extended warranty is available at time of purchase.

Service

At end of 12-month warranty period a service contract is available upon request.

Rental option includes Service & Maintenance for full term.

Approvals

- OTCR Compliant, City of New York
- LAETL In Approval, LARR#Pending, City of Los Angeles
- ISO Compliant
- California Seismic Code Compliant
- Miami Dade County Compliant
- Approved in multiple US cities

PRODUCT MODELS

MODEL LS2h0d

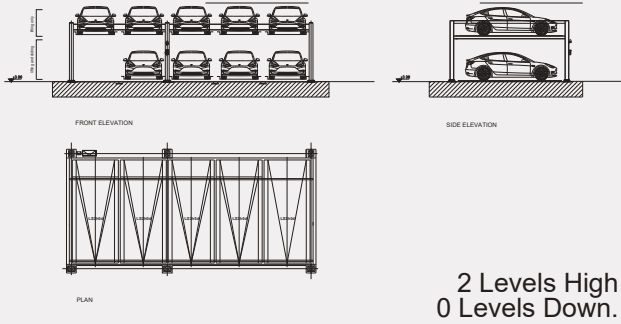

MODEL LS3h0d

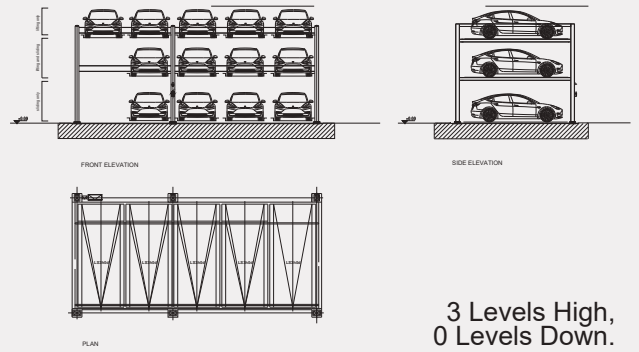

MODEL LS2h1d

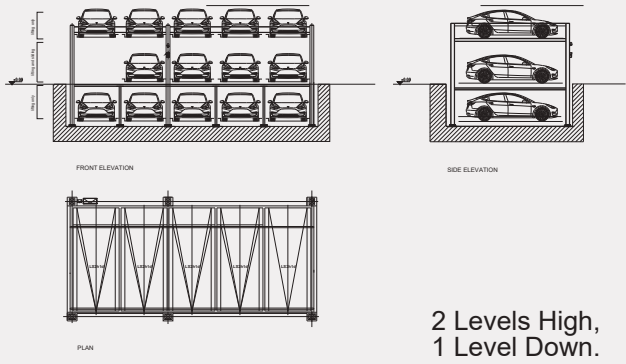

MODEL LS3h1d

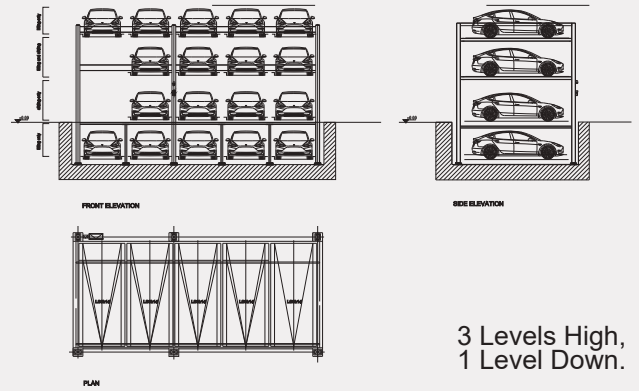

MODEL LS2h2d

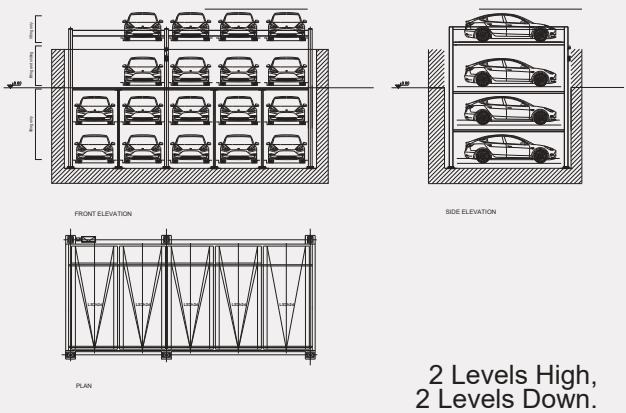

MODEL LS3h2d

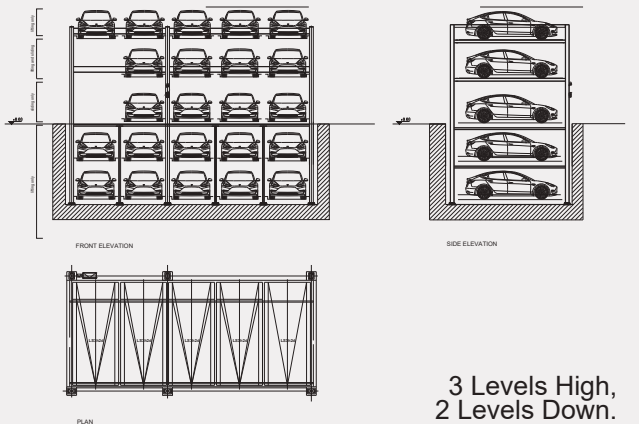

Layout

PARKPLUS LS Lift-Sliding System can be arranged in single or tandem arrays, with or without Pit, on either side of a drive aisle.

TYPE	Sedan	SUV
Pit Depth	7'-3"	9'-0"
On Grade	6'-8"	6'-8"
Above Grade	5'-2"	6'-8"

*Custom dimensions available.

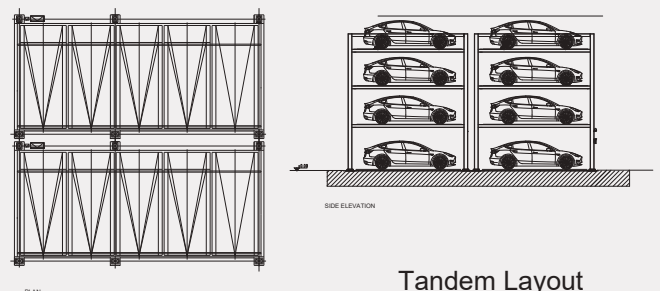

PRODUCT MODELS

MODEL LS4h0d

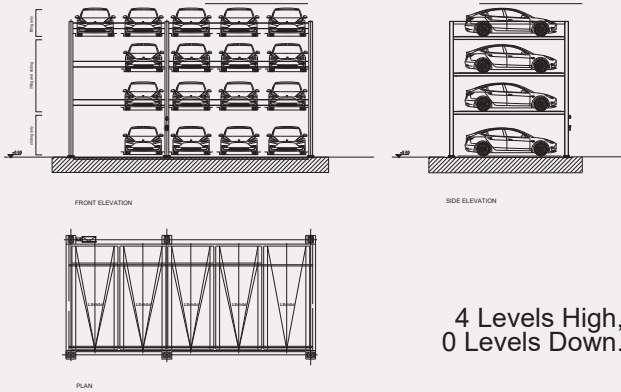

4 Levels High,
0 Levels Down.

MODEL LS5h0d

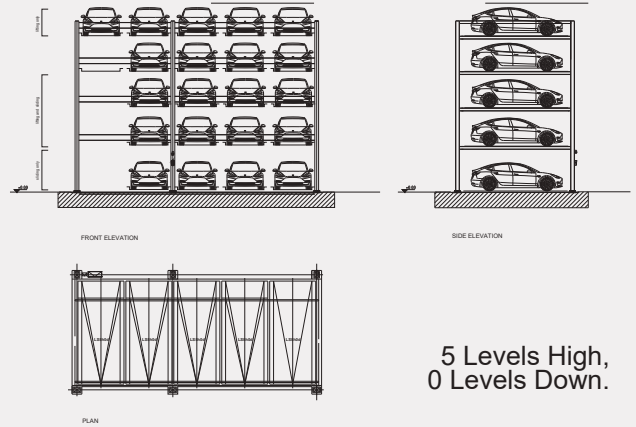

5 Levels High,
0 Levels Down.

MODEL LS4h1d

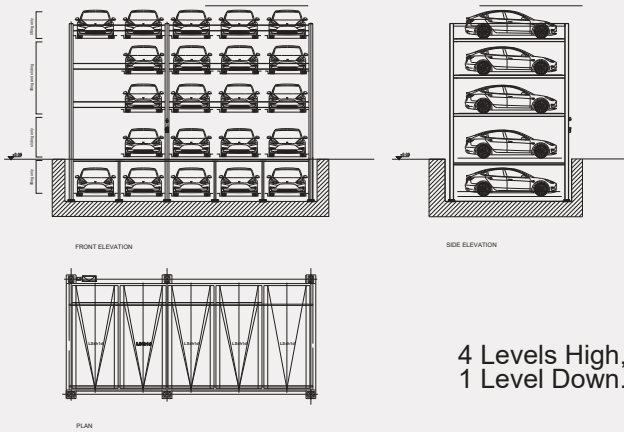

4 Levels High,
1 Level Down.

MODEL LS5h1d

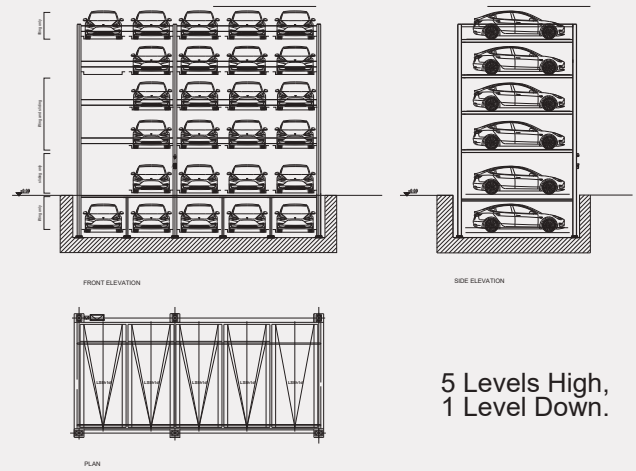

5 Levels High,
1 Level Down.

MODEL LS4h2d

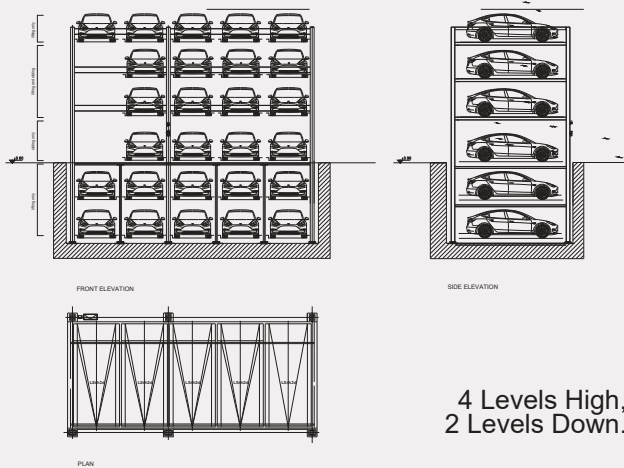

4 Levels High,
2 Levels Down.

MODEL LS5h2d

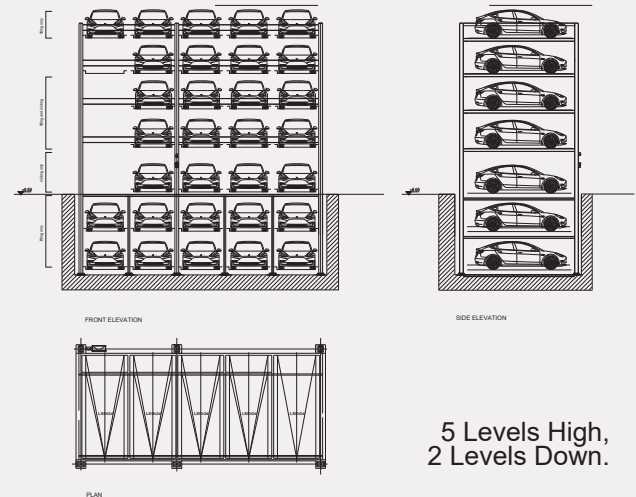

5 Levels High,
2 Levels Down.



MECHANICAL
ATTENDED SYSTEMS
FOR BASIC STACKING



AUTOMATED
ADVANCED TECHNOLOGIES FOR
ROBOTIC PARKING SOLUTIONS



SEMI AUTOMATED
HYBRID DESIGN FOR
SELF-PARK OR ATTENDED STACKING



CUSTOM UNITS
CREATIVE SOLUTIONS FOR
CUSTOM DESIGN & EXPOSURE

INFO@PARKPLUSINC.COM

OUR GLOBAL FOOTPRINT



CALL US: **8-444-PARKPLUS**



PARKPLUS, INC. HEAD OFFICE
83 BROAD AVENUE, SUITE 2
FAIRVIEW, NJ 07022

PARKPLUS CALIFORNIA
8640 TAMARACK AVENUE
LOS ANGELES, CA 91352

PARKPLUS FLORIDA, INC.
1111 OLD GRIFFIN ROAD
DANIA BEACH, FL 33004